

INDIAN FACTORY

Service Shots

FOR
Indian Dealers



INDIAN DEALER
No. 116
May 27, 1940

STEP UP THE POWER AND PERFORMANCE OF
YOURS AND YOUR RIDERS' 1939
AND EARLIER MAGNETO EQUIPPED MACHINES
Special Factory Conversion Offer

Because of the really superior performance and extra power developed by using the new 1940 type Indian magneto on older equipment, we have prepared the following conversion sets of parts to make this conversion.

These are offered to you at a special price - and this offering is good until further notice. Prices, of course, are subject to change without notice.

Special Conversion Parts to Equip 1932 to 1939 Indian
74 Magneto Equipped Machines with 1940 Magneto Ignition:

<u>Quantity</u>	<u>Part No.</u>	<u>Description</u>
1	75559	Magneto R. H.
1	42961	Drive gear
1	42752	Bushing
1	41557	Spark Plug Wire
1	40397	Spark Plug Wire

Special net conversion price when ordered as a group\$15.00

Complete Instructions for making this conversion are shown on the attached sketch, No. 1.

Special Conversion Parts to Equip 1934 to 1939 Indian
45 Magneto Equipped Machines with 1940 Magneto Ignition:

<u>Quantity</u>	<u>Part No.</u>	<u>Description</u>
1	75560	Magneto L. H.
1	42705	Drive Gear
1	42701	Spark Plug Wire
1	42703	Spark Plug Wire

Special Net Conversion Price When Ordered
as a Group..... \$15.00

Complete Instructions for making this conversion are
shown on the attached sketch, No. 2.

Instructions for Installing 1940 Magneto on older Indian
74 machines (See Diagram No. 1)

1. Remove old magneto, magneto gear, and shaft seal.
2. Drill two (2) new holes in magneto platform as shown on sketch.
3. Press in new magneto gear bushing and ream hole to dimension shown.
4. Install new magneto with new gear and time motor to proper advance.

Instructions for Installing the 1940 Magneto on older Model
Sport Scout 45's. (See Diagram No. 2)

1. Remove old magneto and gear.
2. Drill two (2) new holes in magneto platform as shown on sketch.
3. Install new magneto with new gear and time motor to proper advance.

INDIAN MOTOCYCLE COMPANY

MAGNETO PARTS CHANGE NOTICE

Edison Splitdorf have now standardized on the bushing type front plate and distributor gear, cam and bearing assembly for our magnetos built since 1942. If it becomes necessary to order replacements for either of these two parts for a ball bearing type magneto (see magneto types below), both the front plate and the gear, cam and bearing assembly of the bushing type will have to be obtained.

Please correct your parts books and records as shown below in order to get the matching bushing parts.

<u>Model</u>	<u>Mag. Type</u>	<u>Ball Bearing Type Front Plate</u>		<u>Bushing Type Front Plate</u>	<u>Ball Type Gear</u>		<u>Bushing Type Gear</u>
' 74"	RmG-2 (R.H.)	102318	use	103020	102170	use	103023
45"	RmG-2 (L.H.)	102318	use	103020	102171	use	103022
Four	Rm - 4 (L.H.)	101847	use	103019	101893	use	103021

You will note that the front plates are the same for the 74" and the 45" models, but the distributor gears are different.

Parts Department

(DIAGRAM NO 1)
SERVICE SHOTS 116

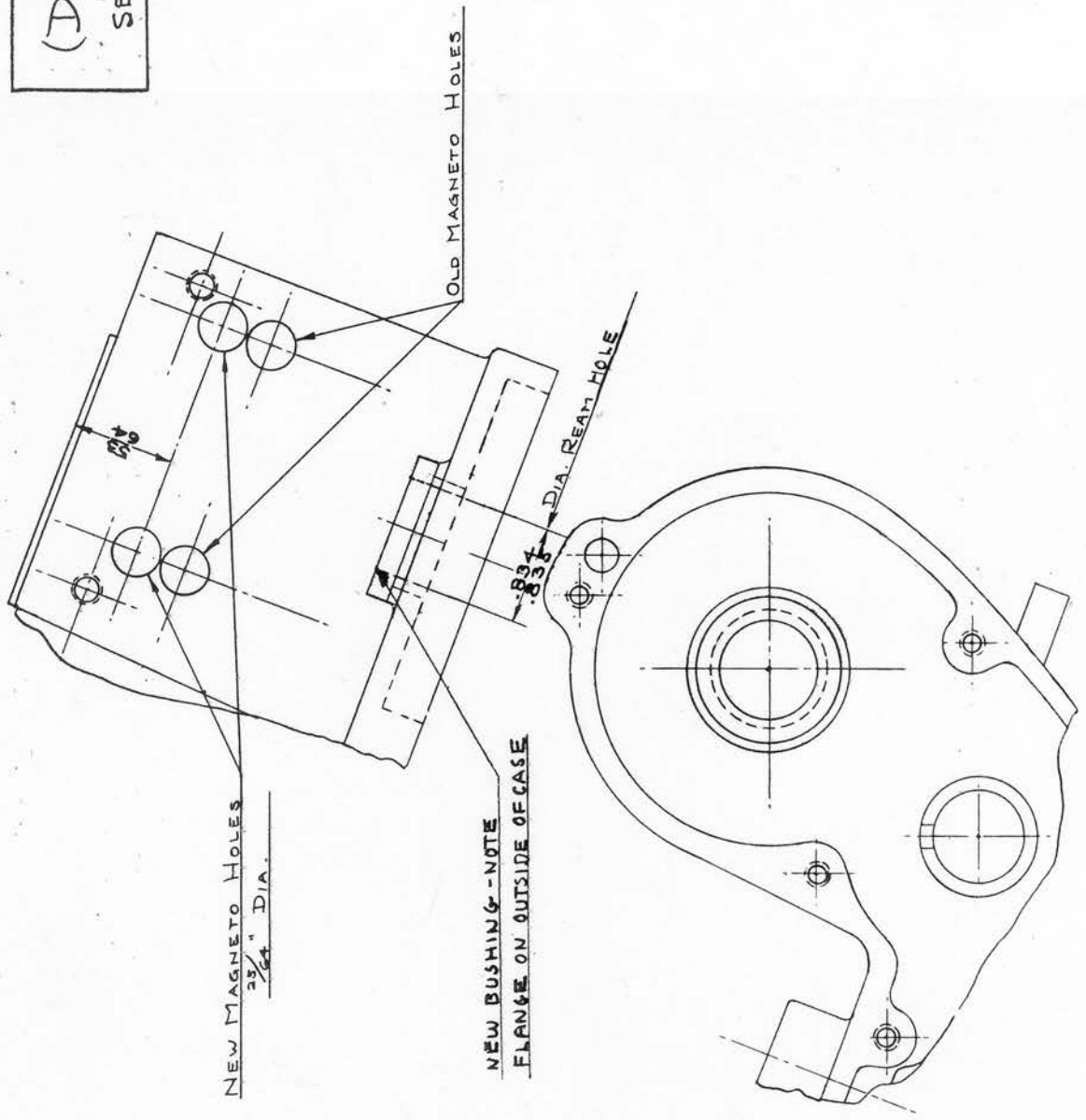

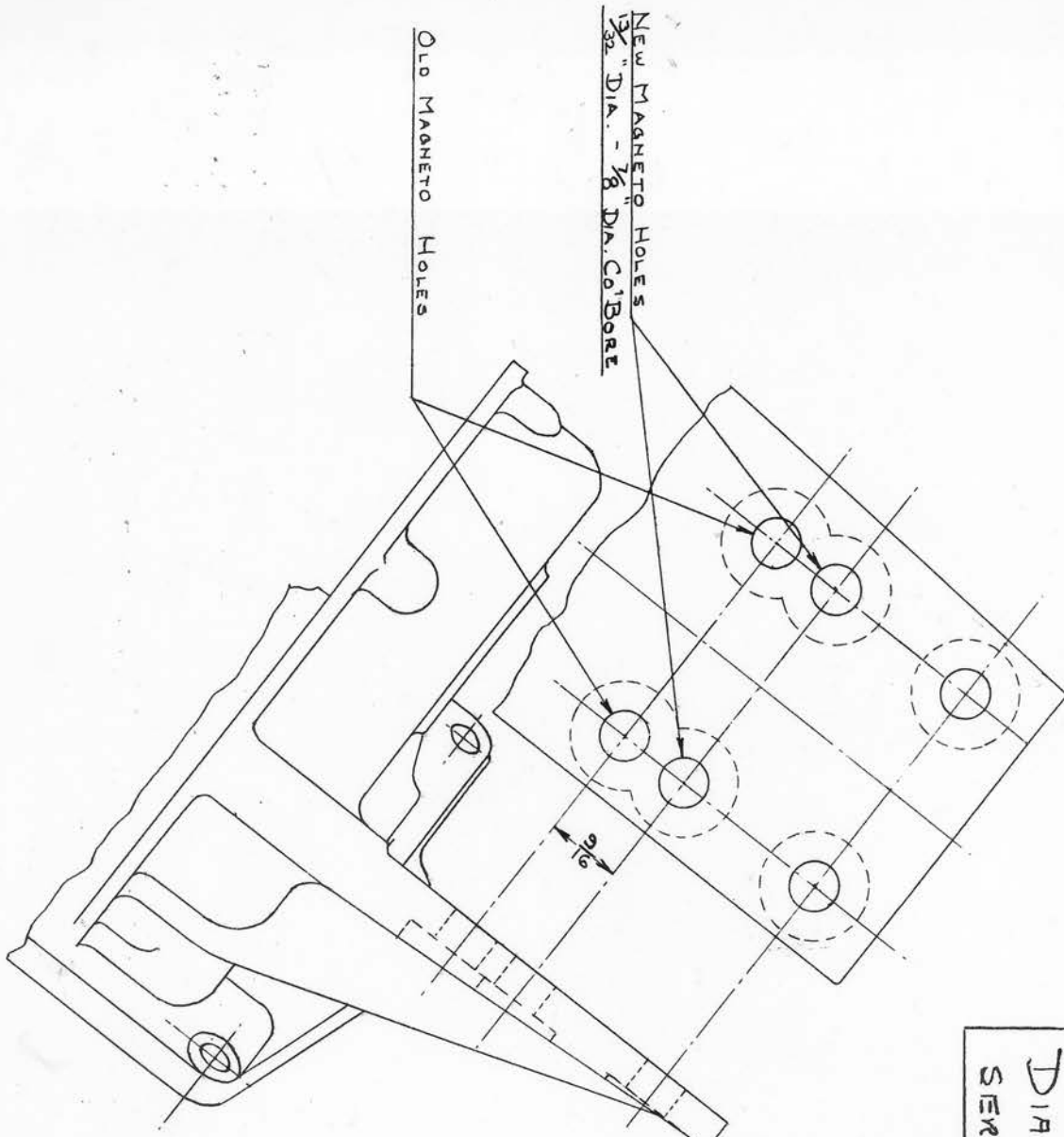

DIAGRAM No 2.
 SERVICE SHOTS No 116